

PLAN
GUARDRAIL FOR HIGHWAY SIGNS⁶

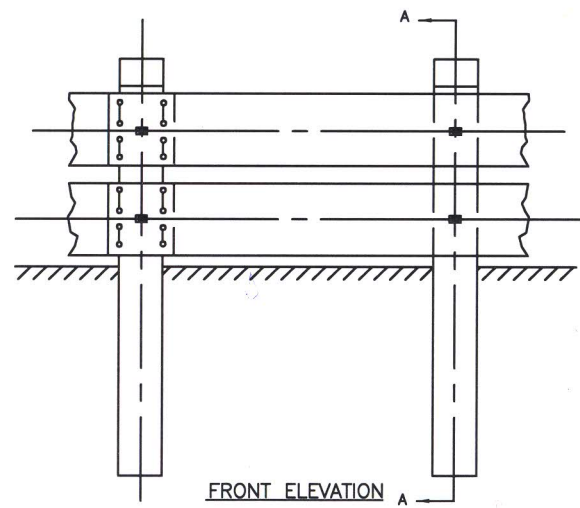

FRONT ELEVATION A

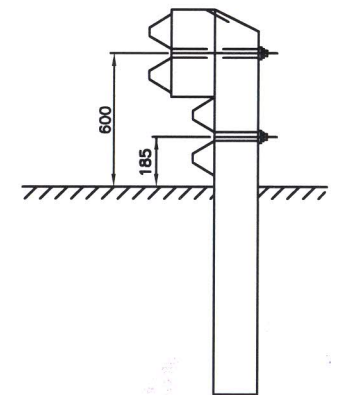

SECTION A-A

- NOTES:
1. THIS DETAIL IS REQUIRED AT APPROACH TO HAZARD ON DIVIDED HIGHWAYS AND ON BOTH APPROACHES ON ROADS WITH TWO WAY TRAFFIC.
 2. ROADSIDE HAZARD IS A BRIDGE FOUNDATION, SIGN TRUSS, CRITICAL EMBANKMENT SLOPE, ETC. INSIDE THE CLEAR ZONE.
 3. POST SPACING AT 1.905m
 4. SEE "TAC GEOMETRIC DESIGN GUIDE FOR CANADIAN ROADS" SEC 3.1.6
 5. SEE STANDARD DRAWING S-2009-072
 6. THIS DETAIL IS ONLY APPLICABLE FOR SIGNS LOCATED WITHIN THE CLEAR ZONE. SEE BEAM DETAIL, BEAM TERMINAL DETAIL, BEAM SPLICE DETAIL, POST AND BLOCK DETAIL, BOLT DETAIL, NOTE 2, NOTE 3, NOTE 4, ON STANDARD DRAWING S-2009-071.
 7. ALL DIMENSIONS ARE IN MILLIMETRES UNLESS OTHERWISE NOTED.

Philip Colburn
 Manager Highway Planning and Design

[Signature]
 Director Highway Engineering Services

[Signature]
 Executive Director Highway Engineering and Construction



No.	REVISION
02	ADDITION OF G-RAIL FOR SIGNS-FEB12
01	REMOVED FLARE INTO DITCH-JAN12

Scale : N.T.S.
 Drawn by : M.LABRECHE
 Checked by : J.RAE
 Date of Plan : AUG2009
 File No. : S-2009-076

**GUARDRAIL MITIGATION OF
ROADSIDE HAZARDS HS524**